



HLK-25005

Heavy Duty Grabber



Features

- Capable of gripping pipe of up to 320mm diameter
- Rotation via a Gerola motor
- 36Nm of torque
- Continuous rotation

Specification:

Dimensions	Length	694mm
	Height	405mm
	Width	91mm
Capacities	Jaw rotate	Continuous
	Torque at 140 bar (across motor ports)	36Nm
	Jaw open/close	320 - 0 mm
Weight	Weight in air	12Kg
	Weight in water	10Kg
Construction		316 Stainless Steel HE 30 Aluminium
Max working pressure		210 BAR
Ports		7/16 SAE

694

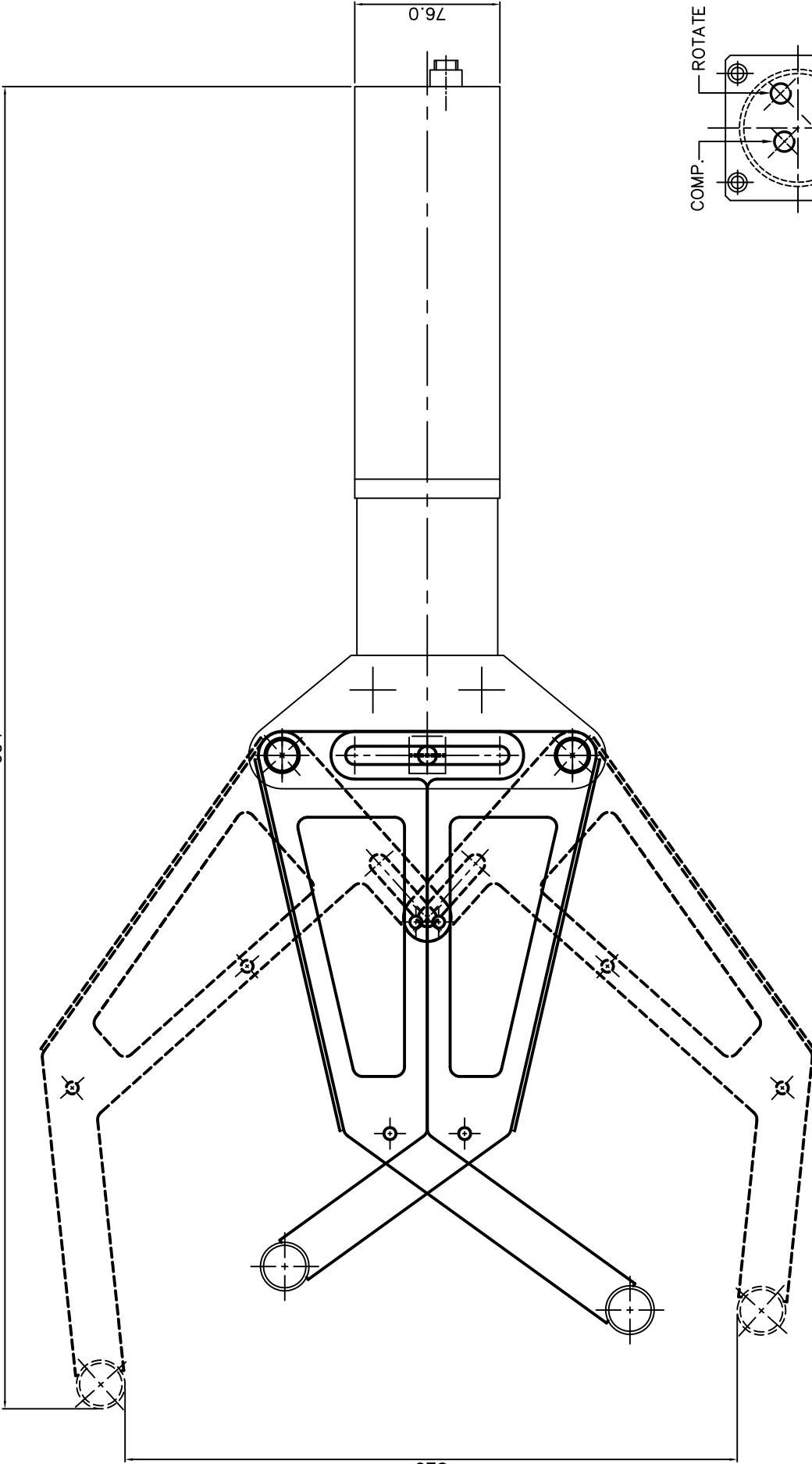

SPECIFICATION :-

JAW ROTATE
 JAW OPEN / CLOSE
 TORQUE AT 140 BAR
 WEIGHT IN AIR
 WEIGHT IN WATER
 MAX. WORKING PRESSURE
 PORTS
 MATERIALS:-

CONTINUOUS
 320 - 0
 36 Nm
 12.0 Kg
 10.0 Kg
 210 bar
 7/16" SAE
 HE 30 HARD ANODISED ALUMINIUM BLOCK
 316 S.S. JAWS ASSY.

VIEW ON CONN. PORTS

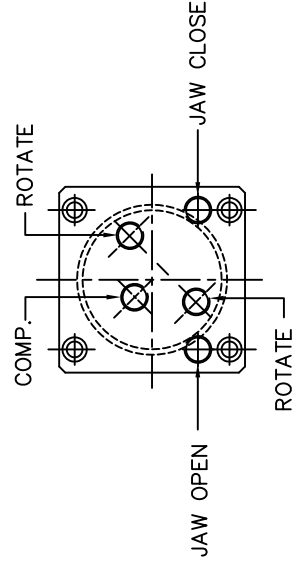

HYDRO-LEK LTD.	HLK-2040 / 25005 H.D. GRABBER
ISS. DATE:-	MAT:-
CHKD BY:-	REV. NO:-1
DRAWN BY:-	PR 4/2/02